

WSs 12-125



Angle Grinder



SERVICE

Tool service and maintenance must be performed only by qualified repair personnel.

When servicing a tool, only use identical replacement parts available from FEIN.

Repairs on FEIN Power Tools required the use of special tools (pulling devices and bearing press). Authorized repair centers have trained repair technicians and equipment necessary to perform these repairs. Service or repairs performed by unqualified persons could result in operator injury.

For the location of the repair center near you, please call 1-800-441-9878. Monday thru Friday, 9AM to 5PM EST. Or, look on our web site at www.feinus.com and follow the link to "Authorized Warranty Repair Centers"

**FEIN Power Tools
1030 Alcon Street
Pittsburgh, PA 15220**

Phone: 412-922-8886 Fax: 412-922-8767 Toll Free: 1-800-441-9878

March 10, 2004

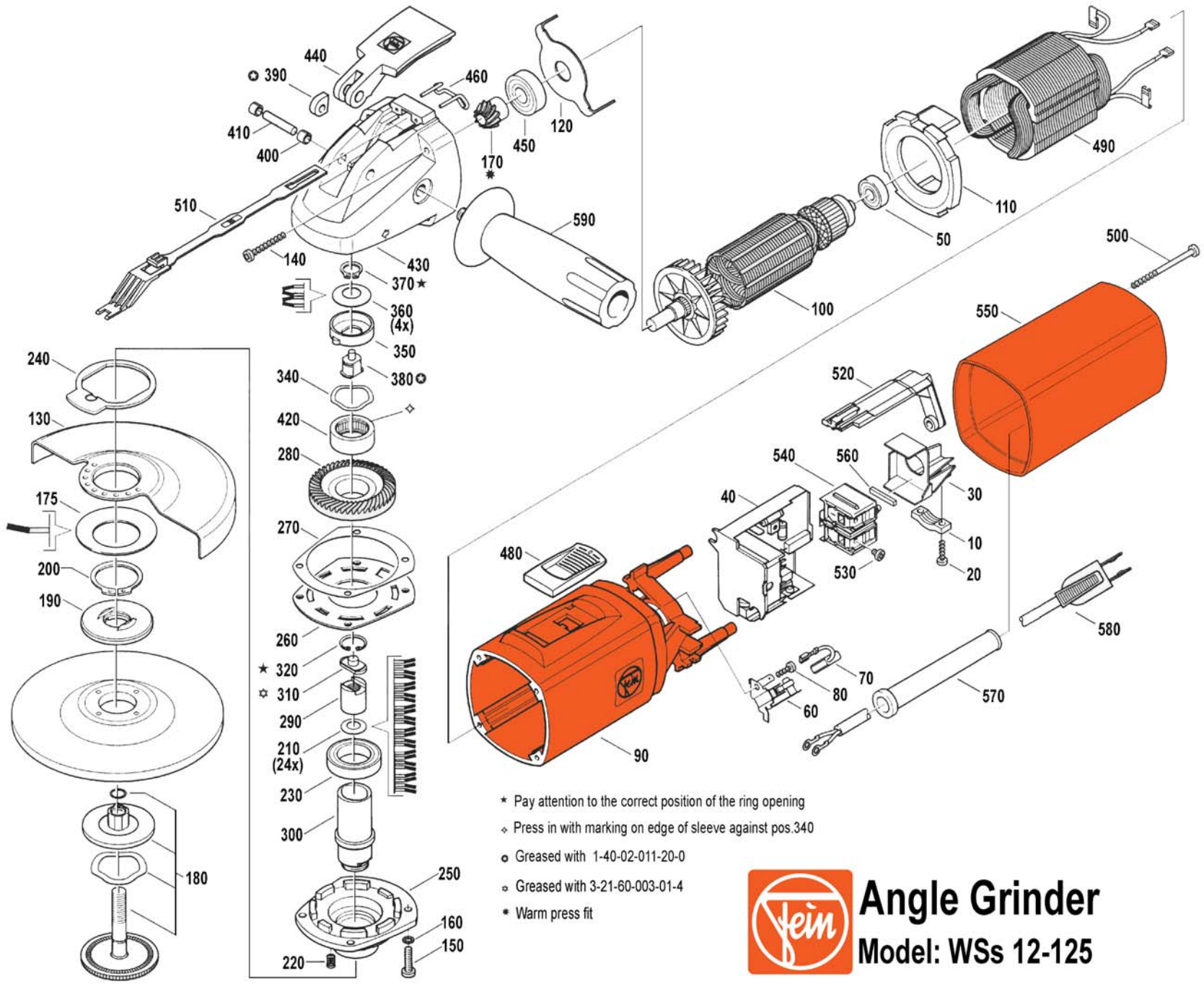

- * Pay attention to the correct position of the ring opening
- ◇ Press in with marking on edge of sleeve against pos.340
- Greased with 1-40-02-011-20-0
- ◊ Greased with 3-21-60-003-01-4
- * Warm press fit

Fein Angle Grinder
 Model: WSs 12-125

FEIN Power Tools

WSs 12-125 Parts List

<u>Item</u>	<u>Item Number</u>	<u>Description</u>	<u>Reqd</u>
10	3-24-31-021-00-7	CLAMP CLAMPING PIECE	1
20	4-30-70-001-00-6	SCREW	2
30	3-24-31-040-00-6	STRAIN RELIEF	1
40	3-07-62-216-99-6	ELECTRONIC (110V)	1
50	4-17-01-001-17-2	BALL BEARING	1
60	3-07-12-088-02-9	BRUSH HOLDER	2
70	3-07-11-136-00-2	CARBON BRUSH	2
80	4-30-70-018-00-9	SCREW	2
90	3-19-01-114-01-4	MOTOR HOUSING	1
100	5-3-273-001-11-7	ARMATURE (110V)	1
110	3-14-28-118-00-7	AIR CONDUCTING RING	1
120	3-24-16-098-00-5	COVER PLATE	1
130	3-18-10-235-00-4	GUARD	1
140	4-30-70-007-00-2	SCREW	4
150	4-30-41-023-04-6	SCREW	4
160	4-24-43-003-04-3	LOCK WASHER	4
170,280	3-38-09-227-01-0	BEVEL GEAR	1
175	3-09-05-070-00-0	CUP SPRING	1
180	6-38-02-178-02-3	CLAMPING FLANGE	1
190	6-38-01-176-01-1	FLANGE	1
200	4-26-16-073-00-5	CIRCLE CLIP	1
210	3-09-05-067-01-5	CUP SPRING (24PCS)	1
220	3-09-01-340-00-1	SPRING	1
230	4-17-01-108-22-2	BALL BEARING	1
240	3-28-05-158-00-0	LEVER	1
250	3-24-19-112-00-0	BEARING PLATE	1
260	3-24-16-099-00-9	COVER PLATE	1
270	3-26-24-116-01-4	SHIM	1
290	3-02-20-056-00-0	THRUST PIECE	1
300	3-34-06-275-00-4	DRIVE SHAFT	1
310	3-24-14-111-00-2	THRUST PLATE	1
320	4-26-16-070-00-9	SECURING RING	1
340	4-24-46-019-00-9	SPRING WASHER	4
350	3-26-36-037-00-8	THRUST PIN	1
360	3-09-05-069-00-8	BREAK DISK	4
370	4-26-16-035-00-1	SECURING PIN	1
380	3-02-17-318-00-2	THRUST PIN	1
390	3-26-36-036-00-4	RING	1
400	3-05-07-220-00-0	BUSHING	2
410	3-02-16-144-00-7	LOCKING BOLT	1
420	4-17-05-032-00-4	NEEDLE BEARING	1
430	3-12-06-107-00-2	GEAR HOUSING	1
440	3-28-05-157-00-2	QUICK CLAMPING LEVER	1
450	4-17-01-007-03-8	BALL BEARING	1
460	3-09-07-062-00-9	SPRING	1
480	3-28-05-156-00-8	SLIDING SWITCH	1
490	5-1-273-001-11-5	FIELD COIL (110V)	1
500	4-30-70-017-00-1	SCREW	2
510	3-28-16-053-00-8	SWITCH LOCK	1

520	3-28-16-052-00-4	SWITCH ROD	1	_____
530	4-30-41-039-09-9	SCREW	2	_____
540	3-07-01-218-00-3	ON/OFF SWITCH	1	_____
550	3-12-01-100-00-9	COVER	1	_____
560	3-14-15-082-00-4	BOLSTER	1	_____
570	3-14-13-007-00-7	PROTECTIVE SLEEVE	1	_____
580	3-07-05-035-01-3	CABLE	1	_____
590	3-21-19-107-01-6	HANDLE	1	_____